

# The TuBore™ 48 Series

## Clean Valves for the Biotech Industry



## The TuBore™ 48 Series

The TuBore™ line is Habonim's clean ball valve for the biotech industry. The valves comply with the ASME BPE and ASME B16.34 standards for applications in which cleanability and drainability are essential for product quality. The standard, highly durable stem seal for all TuBore™ valves is Habonim's patented HermetiX™. Made solely from FDA-approved polymer materials, the HermetiX™ stem seal enhances productivity and safety by virtually eliminating leaks, shutdowns, hazardous spillage, etc. It comes with a maintenance-free warranty of 4 years or 500,000 cycles. The TuBore™ valve port diameter is identical to the inner diameter of the tube so that no expansion or contraction can take place inside the system, resulting in full drainage and zero traces that could cause contamination. TuBore™ valves are produced from forged 316L stainless steel with a ferrite content of less than 1% and a controlled sulfur content between 0.005% and 0.017%. This provides superior weldability, and prevents rouging, and corrosion of welds.

### 48X series TuBore™ with ISO 15848-1 certified stem seal

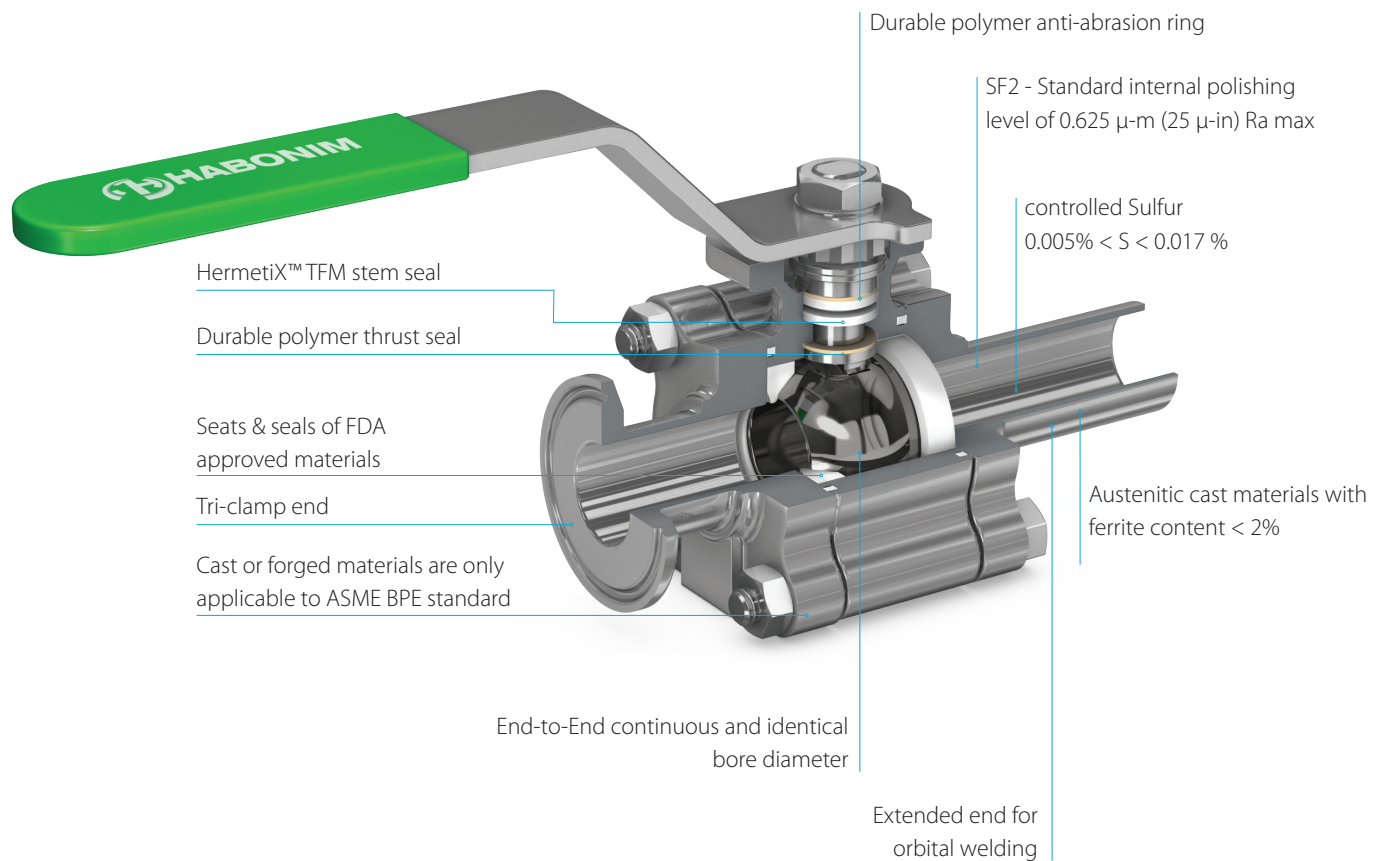

**The HermetiX™ stem seal enhances productivity and safety by virtually eliminating leaks, shutdowns, hazardous spillage, etc.**

## Features of the Tubore™ Clean Biotech Valve Series

- **Maximum flow capacity.**
- **Minimum pressure drop.**
- **Low-torque and bubble tight shutoff capabilities.**
- **Certified for fugitive emission to ISO 15848-1 standard.**
- **Stem seal maintenance-free warranty of 4 years or 500,000 cycles.**
- **Forged 316L stainless steel with a ferrite content of less than 1% and a controlled sulfur content between 0.005% and 0.017 %, as standard.**
- **Superior materials (EN 10222-5 1.4435 (316L), A494 CX-2MW Alloy C22, and A494 CX-12MW Alloy C276) available upon request.**
- **Internal surface of valve is mechanically polished to 25 µ-in Ra max as standard, higher surface finishes up to 20 µ-in Ra (max) available upon request, as well as electro-polishing of valve body and ends.**

## Cleaning, Assembly, Testing and Packaging

Habonim's meticulous cleaning, assembly and inspection procedures for the TuBore™ line ensures the stringent cleanliness required by biotech services.

All particles, grease, metal chips and other contamination hazards are removed thoroughly before the assembly process begins. The valves are assembled in an oil free restricted area by specially trained & qualified personnel. All valves are 100% helium leak tested. Packaging is done in the same cleanroom where the cleaning process was completed. Finished valves are removed from the cleanroom environment only after being bagged and sealed in a clean polyethylene bag.

## Certifications and standards of compliance

<b>Factory certification</b>	<b>ISO 9001-2008</b>	Quality management system
<b>Valve design &amp; tests</b>	<b>ANSI B16.34</b>	Valve design
	<b>ASME BPE</b>	Valve design
	<b>DIN 11850 (Range 2)</b>	Stainless steel tubes - Dimensions and tolerances
	<b>ISO 1127</b>	Stainless steel tubes - Dimensions and tolerances
	<b>EN 12266-1, API 598</b>	Testing of metallic valves - Pressure tests, test procedures and acceptance criteria.
	<b>ISO 15848-1</b>	Industrial valves - measurement, test and qualification procedures for fugitive emissions
	<b>PED 97/23/EC Module H</b>	Pressure equipment directive
	<b>ATEX 94/9/EC</b>	Equipment and protective systems intended for use in potentially explosive atmospheres (optional for actuated unit only)
<b>Documentation</b>	<b>EN 10204 2.2 / 3.1 / 3.2</b>	Metallic materials - types of inspection documents

# VALVES ACCESSORIES



Spring Return Handle (SRH)



Fugitive Emission (FE)



Spring-Loaded Locking Device (LD)



Pneumatic Actuator



Breather Block



IMPACT™ Spring Assist



CAT - BIOTECH 07/16  
MAXMARK

**HABONIM**  
Industrial Valves & Actuators  
[www.habonim.com](http://www.habonim.com)



[www.habonim.com](http://www.habonim.com)



HermetiX FS



**Habonim Israel**  
Tel: +972 4 6914911 / 6914903  
Fax: +972 4 6914935  
[sales\\_international@habonim.com](mailto:sales_international@habonim.com)

**Habonim USA**  
Toll Free Phone: 1 866 261 8400  
Toll Free Fax: 1 866 243 9959  
[sales\\_usa@habonim.com](mailto:sales_usa@habonim.com)

**Habonim EU**  
Tel: +34 640 384 759  
[sales\\_international@habonim.com](mailto:sales_international@habonim.com)

**Habonim China**  
Tel: + 86 21 64453190 \*146  
Fax: + 86 21 64453191  
[sales\\_china@habonim.com](mailto:sales_china@habonim.com)

**Habonim UK**  
Tel: +44 1633 484554  
Fax: +44 1633 482252  
[sales\\_uk@habonim.com](mailto:sales_uk@habonim.com)

**Habonim Australia**  
Tel: +61 3 9556 5428  
[sales\\_au@habonimau.com](mailto:sales_au@habonimau.com)